

**Manufacturer of Twin Lobe Roots Blower,  
Cement Bulker Unloading System,  
Cement Feeding System,  
Twin Lobe Air Compressor.**

[www.honestrootsblower.com](http://www.honestrootsblower.com)



**HONEST ENTERPRISE**

*Honesty is the Soul of Business*



## Bulker Unloading System

We manufacture and supply a Bulker Unloading System (Twin Lobe Cement Silo Compressor) of the highest possible quality. Applications like cement plant, water treatment plants, chemical plants, aquaculture, paper plants, oil & gas, vacuum loader, and electroplating make use of the twin lobe roots air compressor or blower that we offer. In accordance with industry standards, we manufacture this blower using high-quality components and cutting-edge technology.

### Features

- Hassle-free operation with negligible maintenance
- Air Cooled
- Improved volumetric efficiency and reduced operating temperatures
- Large inlet and outlet connections for minimum loss
- High efficiency with the optimum rotation
- Constant volume of air even in the case when pressure varies
- High static pressures due to its lightweight construction
- Specific designs of lobes are available to provide continuous air flow
- V-Belt Driven

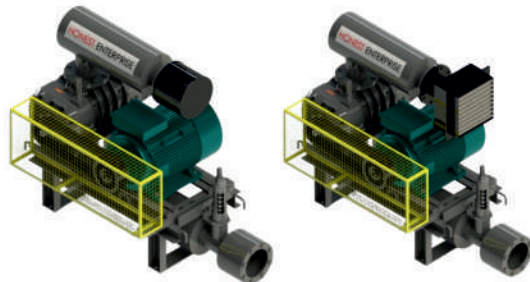

### Specification :

<b>Automation Grade</b>	: Semi-Automatic
<b>Usage/Application</b>	: Industrial
<b>Driven Type</b>	: Electric
<b>Voltage V</b>	: 440 V
<b>Frequency</b>	: 50 Hz
<b>Phase</b>	: 3 Phase

## Dual Cement Feeding System

We are involved in providing a Dual Cement Feeding System (Fly Ash Feeding System) of superior quality that is precisely manufactured using components of superior quality and cutting-edge technology in full compliance with established international quality standards. At Batching Plant sites, we offer a packaged system for conveying, feeding Cement and Fly Ash into silos. The offered product is tested against a variety of quality parameters to ensure that it satisfies all of our valued customer's requirements.

### Features

- Variable flow rate and operation mode
- Continuous operation with adjustable vibrating force
- Provides high degree of sanitary environment
- Smooth operation, high efficiency and long service life
- Stable vibration with high feeding capacity
- Trouble free functionality
- Requires less maintenance due to rugged construction
- V-Belt Driven

### Optional Accessories

- Dust Collection System
- Control Panel
- Hose Pipes
- Cartridges for Dust Collection System

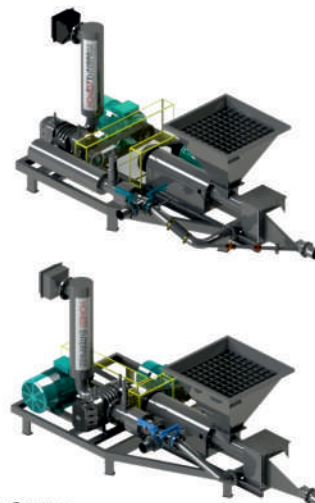

**Specification :** Two commonly preferred options are designed and manufactured by us in our state-of-the-art modern facility.

Specification	Feature	Power HP	Rate in T/Hr. (For Bags)	Rate in T/Hr. (For Bulker)
CFS-1	Screw Pump	70 (30 + 40) 30 HP for Screw 40 HP for Blower	21-24	24-30
CFS-2	Screw Pump	80 (30 + 50) 30 HP for Screw 50 HP for Blower	24-30	30-40



## Manual Bag Feeding System

We are involved in providing a Manual Cement Feeding System (Fly Ash Feeding System) of superior quality that is precisely manufactured using components of superior quality and cutting-edge technology in full compliance with established international quality standards. At Batching Plant sites, we offer a packaged system for conveying, feeding Cement and Fly Ash into silos. The offered product is tested against a variety of quality parameters to ensure that it satisfies all of our valued customer's requirements.

Specification	Feature	Power HP	Rate in T/Hr. (For Bags)	Rate in T/Hr. (For Bulker)
CFS-1	Screw Pump	30 HP for Screw	21-24	24-30

### Features :

- Variable flow rate and operation mode
- Continuous operation with adjustable vibrating force
- Provides high degree of sanitary environment
- Smooth operation, high efficiency and long service life
- Stable vibration with high feeding capacity
- Trouble free functionality
- Requires less maintenance due to rugged construction
- V-Belt Driven

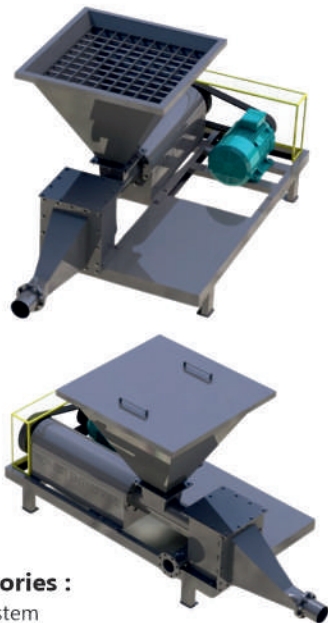

### Optional Accessories :

- Dust Collection System
- Control Panel
- Hose Pipes
- Cartridges for Dust Collection System

## Twin Lobe Roots Blower

As the leading manufacturer of the highly demanded Twin Lobe Roots Blower, we have gained widespread acclaim. Our offered high-performing roots blower has a high air flow rate and is widely used in the process industries. Because the main gas chambers are separated from the lubricating chambers, oil-free air is delivered. In addition, the highly effective equipment, which can be ordered according to specific requirements, produces optimal pressure.

### Special Features :

- Machines are air cooled, hence water cooling is not required
- Positive displacement machine with constant volume characteristic
- High precision helical timing gears for reliability and long life
- Overhung V-Belt drive for all operating pressure ranges.  
Direct coupling also possible
- Dynamically balanced rotating components to ensure vibration free operation
- Suitable for various gasses such as air, town gas, natural gas, nitrogen gas, carbon dioxide, inert gasses Solid noise-absorbing Construction in gray cast iron
- Special air filters are provided depending upon the application and working environment
- V-Belt Driven



**Blower Speed : 1200 to 2800 RPM**  
**Air Flow : 50 m<sup>3</sup>/hr to 2000 m<sup>3</sup>/hr**  
**Motor Power : 1 HP to 100 HP**  
**Surface Finish : Color Coating**

# ABOUT US

Honest Enterprise is a Trusted Manufacturer & Supplier of Twin Lobe Blower, Twin Lobe Compressor, Twin Lobe Air Compressor, Twin Lobe Roots Blower, Bulker Unloading System, Fly Ash Unloading System and also supplier of all types Construction Equipment's for silo (for Cement & Fly Ash Storage), Belt Conveyor, Dust Collectors and other related construction equipment's. We are committed for fabricating Machinery under strict Quality Constraints so as to deliver best products to the clients. How we are your one stop solution to all Construction Equipment's for your needs and supplier of customized solution's machinery at competitive market prices.

Our experienced staff and all products are manufactured are conforming to international quality standards. We are capable to deliver bulk order within stipulated time.

Our Experienced Team of Research and Development Professionals works constantly to further improve the quality of our products and services. We boast of a strong market presence and good network which helps us maintain a good reputation in the industry and reach out to a wider client base.

## OUR MISSION

Striving to be a leader in our field by making innovative products with Superior Quality, collaborating with customers to reduce costs and build basis for Mutual Collaboration, and Intensifying our efforts towards ongoing financial stability and profitability.

## OUR VISION

Honest Enterprise is committed to consistent development. Thereby building a stable, global institution - with the resources to deliver the products as per customer's requirements. We offer unparalleled value to create customer delight and enhance business productivity.

## SERVICE

We, The Team of Honest Enterprise are always Committed to serve our clients providing On Site Installation, Maintenance and other services.



**Manufacturer of Twin Lobe Roots Blower, Cement Bulker Unloading System, Cement Feeding System, Twin Lobe Air Compressor.**



*Honesty is the Soul of Business*

## HONEST ENTERPRISE

B/14, Saudhariya Estate, Patel Timber, Nr. Hathijan Circle,  
Jashoda - Hathijan Road, Ahmedabad - 382445

Phone : +91 - 99748 32820, +91 - 76004 42820, +91 - 63547 38049

Email : [info@honestrootsblower.com](mailto:info@honestrootsblower.com), [honestenterprise2411@gmail.com](mailto:honestenterprise2411@gmail.com)

Web : [www.honestrootsblower.com](http://www.honestrootsblower.com)